

1 1/2" - 3000# H.C.
W/STL. PLUG
INSP. OPENING
(2) PLC'S.

TOP L.S. @ 270°
LOWER L.S. @ 45°

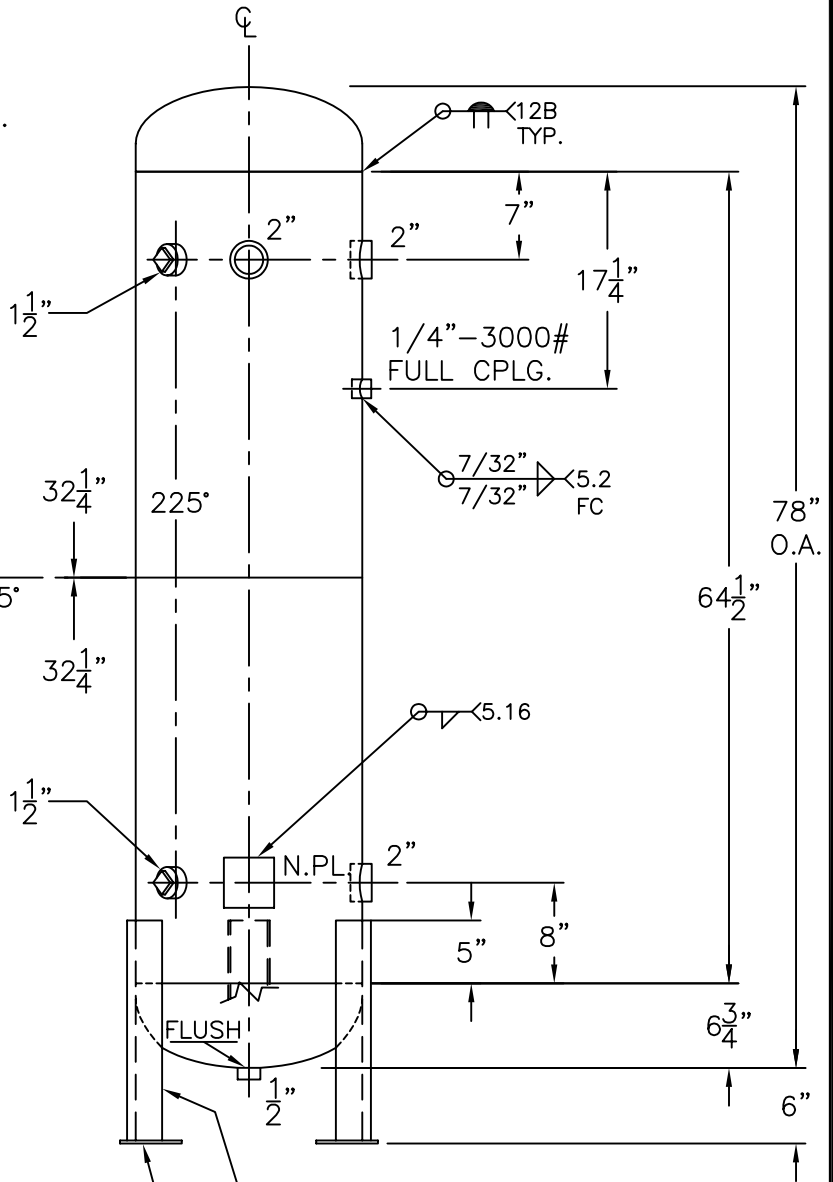

(3) 2 1/2" x 2 1/2" x 1/4" THK.
x 17 1/2" LG. ANGLE LEGS

(3) 4" x 4" x 1/4" THK.
PAD W/ 3/4" Ø HOLE

(2) 1 1/2"
IN LINE

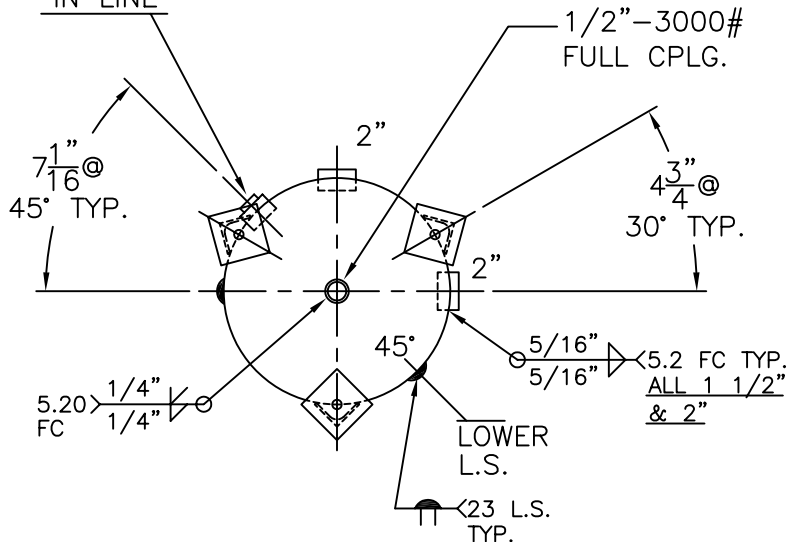

- NOTE: 1) HYDRO @ 1430 PSIG. MIN.
2) PRE HEAT BEFORE WELDING TO 150°F.
3) IMPACT TESTED? NO UG-20(f)
4) CRN ALBERTA #U8774.2

SHELL / HEADS	
.500" SA-516-70	2:1 S.E.
(.472" MIN.)	
M.A.W.P.	1100 PSIG. @ 400 °F
M.D.M.T.	-20 °F @ 1100 PSIG.
ASME SECTION VIII	DIV. 1, 2007 ADD 2008
X-RAY: RT-2	100% L.S. SPOT ALL G.S.
GALLONS: 73	WT. 670 LBS.
SERIAL NO.	
N.B.	

18-VY-73-1	REV. 5-13-09
FOR: HANSON STANDARD	DATE: 12-28-84
VERT. AIR TANK	
INSIDE: UNPAINTED	
OUTSIDE: PRIME	
LEG-ZONE 4-15 KM.	
BY: J.G.	SCALE: 3/4" = 12"
ROY F. HANSON JR. MFG.	
1600 E. WASHINGTON BLVD.	
LOS ANGELES, CA 90021	